

www.nationaltrailerparts.com

IN THIS ISSUE

Hi Spec Series 07 Aluminum Wheels	2
Curt Weight Distribution Hitch	2
Tekonsha Prodigy P2 Brake Control	3
Diversa-Tech Locking Aluminum Ball Mount	3
Profit Center Program	4
Stocking Dealer Program	5
Convert-A-Ball Offset Adapter	6
Convert-A-Ball Adjustable Adapter	6
Wallace Forge Drilled King Pin	7
Bergen Slide Lock Coupler	7
Mumby Ease-Glide Channel Coupler	7
Marine Products Catalogue	8

What Shape is Your Catalogue In?

Pages falling out?

Binder getting gross?

Running out of room for extra notes & doodlings?



If it is time for a new catalogue - or you would like to access our online catalogue - contact your sales rep or email us at mike@trailerparts.ca

www.nationaltrailerparts.com

SELECTION SERVICE SUPPORT

Hello everyone. We hope you had a wonderful summer and that you are all "raring to go" as we head into the last quarter of 2011!

Judging by the level of activity we see (and from what you are telling us), it seems to us that the Western Canadian trailer and agricultural machinery business is producing an encouraging amount of business for you.

Perhaps the theme for our businesses in the months ahead should be "Yes we can thrive, thank you very much"!

The business headlines often scream about fear. Be afraid of US debt! Be afraid of Eurozone contagion! Be afraid of a double dip!

While we would never advocate being unaware of risk in business, it would appear that opportunity exists throughout our sector. Wouldn't it be a shame if we listened to the fear mongers and stuck our heads in the sand!

The leading indicators we look at include:

Continued strength in the agricultural grain sector. Many areas will have harvested good to great crops in very good condition. Commodity prices remain strong, suggesting good cash flow and product demand well into 2012.

The energy sector, particularly oil, presents a very encouraging picture of continued strong growth. These guys spend a lot of money, all over Western Canada, when they grow by the drill bit.

Residential and commercial construction, while not as backed up as in 2006 and 2007, is robust throughout our area.

Canada, as a whole, is in great economic shape.

Yes, there are risks out there in the real world. Caution is a good word. But there is much opportunity right now, right in our backyards.

At National Trailer Parts we are governed by one primary motivation; serving your needs to make your businesses more successful!

We hope we can continue to work with you in this way; exploiting opportunity for success. Your success!

Thank you for your business and your trust!

The Team at National Trailer Parts.



2494 South Service Rd W, Swift Current, SK S9H 5J8
Phone: (306) 773-4484 / Fax: (306) 773-6080



HISPEC SERIES 07 ALUMINUM TRAILER WHEELS



- Many late model pickups and SUV's come equipped with similarly designed wheels. The 07 Series have an attractive gun metal gray paint on aluminum spoke, with heavier, wet clear coat finish for added corrosion resistance.
- Pre-installed steel hole inserts, uses standard size lugnuts and is safer, less expensive and easier to use.
- With an open lug nut design, the lugnut holes are big enough to use a 4-way lug wrench, no special tools required.
- Wheels arrive clean and undamaged, packed in individual corrugated boxes, ready for installation or retail sales; featuring IFC Technology - no need to re-torque.



Part No.	Ref. No.	Description
WH135-507A	326610	13 X 5, 5 ON 4.5, 319 PILOT, 1660 LBS, SERIES 07
WH1455-507A	326708	14 X 5.5, 5 ON 4.5, 319 PILOT, 1900 LBS, SERIES 07
WH155-507A	326709	15 X 5, 5 ON 4.5, 319 PILOT, 1820 LBS, SERIES 07
WH156-607A	326728	15 X 6, 6 ON 5.5, 4.25 PILOT, 2830 LBS, SERIES 07
WH166-607A	326737	16 X 6, 6 ON 5.5, 4.25 PILOT, 3200 LBS, SERIES 07
WH166-807A	326750	16 X 6, 8 ON 6.5, 4.90 PILOT, 3960 LBS, SERIES 07

WEIGHT DISTRIBUTION HITCH



Ideal for use when towing trailers with heavier tongue weights. A Weight Distribution Hitch applies leverage between the tow vehicle and trailer resulting in a more level ride with less stress on the rear of the tow vehicle. Use with a 2" receiver hitch. Rated at 10,000 lbs. towing capacity.

Part No.	Ref. No.	Description
17002	318078	WEIGHT DIST HITCH, 10 K ROUND BAR, ADJUSTABLE SHANK
17200	318084	SWAY CONTROL ARM & BALL, USE WITH WEIGHT DIST HITCH
17108	318090	LIFT BRACKET KIT FOR WEIGHT DIST HITCH - PAIR

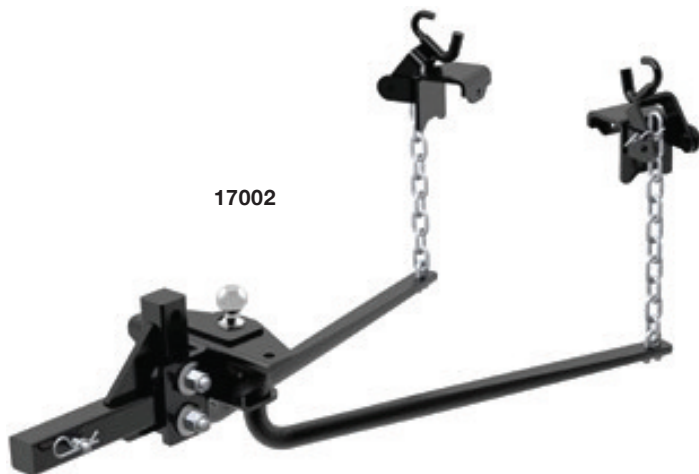

PRODIGY P2 BRAKE CONTROL



- Self-leveling motion sensor adjusts to varying terrain as you drive.
- Easy to read LED displays voltage delivery to trailer during diagnostics & braking mode.
- On-board diagnostics with built in digital volt ohm meter checks for output short circuit, open ground, output overload & power loss; displays a flashing warning on a red screen to alert the user.
- Choice of electric or electric over hydraulic brake mode, showing E or H in lower left corner of display.
- 3 boost levels provide more aggressive braking for heavier trailers.
- Easy center mount design provides a quick disconnect and allows for multiple vehicle use.
- Plug & Play Installation eliminates hard-wiring in vehicles with OE tow package connections.
- Inertia sensor allows proportional braking in reverse without using a manual lever and can also be disabled.
- Multiple mounting options allows a 360 degree vertical rotation.



Part No.	Ref. No.	Description
90885	416634	PRODIGY BRAKE CONTROL P2 1-4 AXLES

10K LOCKING ALUMINUM BALL MOUNT

- Fast adjustments & superior theft protection with integrated dual self-locking system.
- Double sealed lock cylinder design provides 100% water & corrosion resistance. Never needs to be internally lubricated or maintained.
- Anti-rattle system reduces noise & hitch wear.
- Rated 10K trailer & 1.5K tongue capacity.



Part No.	Ref. No.	Description
DT-ALBM6600	319652	ADJUSTABLE LOCKING BALL MOUNT 6" DROP, 2" & 2 5/16 BALLS
DT-ALBM7000	319654	ADJUSTABLE LOCKING BALL MOUNT 10" DROP, 2" & 2 5/16 BALLS



PROFIT CENTER PROGRAM



National Trailer Parts has developed parts selections to help you start your own Trailer Parts Department.

Whether you are just starting out, or trying to simplify or clean up your existing parts selection, we can help.

If our standard packages do not suit your needs, we can develop selections and displays that fit your needs.



"We can help you tailor a program that fits your business, your market area, your people and your facilities."

Ron Elkington
ron@trailerparts.ca
855-778-7310

Profit Center Inquiries

STOCKING DEALER PROGRAM



“Whether you have people and facilities that are underutilized, or if you are trying to think of ways to expand your products and services”

You Provide:

- Preferred location and facilities.
- Knowledgeable Staff.
- Local market expertise.
- A desire to grow your business.

We Provide:

- Unparalleled Service to your business and customers.
- The largest selection of product in our market segment.
- Professional support to your staff and customers.
- A desire to create a lasting relationship with your business.



Stocking Dealer Inquiries

Mike Heschel
mike@trailerparts.ca
855-778-7309

5TH WHEEL TO GOOSENECK OFFSET ADAPTER

CONVERT-A-BALL®

Converts your 5th Wheel Trailer to a Gooseneck Trailer; allows Gooseneck Hitch owners to pull 5th Wheel Trailers.

- Additional towing flexibility - cushioned 360°
- 7 1/2" Offset
- C5GX1214 is adjustable from 12" to 14"
- Patented polyurethane insert cushion system reduces road vibrations & bumps
- Safety chains included with each unit
- Tested & Certified 20K GVW and 4K Tongue
- Coupler secures with a standard padlock



Designed for Short Bed Trucks to Increase Turning Clearance

All Units Have Patented Positive Lock Coupler

Part No.	Ref. No.	Description
C5GX1214	314622	5TH WHEEL TO GOOSENECK ADAPTER, OFFSET, 12" - 14" ADJUSTABLE CUSHIONED, 20K

5TH WHEEL TO GOOSENECK ADAPTER

Converts your 5th Wheel Trailer to a Gooseneck Trailer; allows Gooseneck Hitch owners to pull 5th Wheel Trailers.

- Additional towing flexibility - cushioned 360° & adjustable from 12" to 16"
- Patented polyurethane insert cushion system reduces road vibrations & bumps
- Safety chains included with each unit
- Tested & Certified 20K GVW and 4K

CONVERT-A-BALL®



Part No.	Ref. No.	Description
C5G1216	314620	5TH WHEEL TO GOOSENECK ADAPTER, 12" - 16" ADJUSTABLE CUSHIONED, 20K

DRILLED KING PIN

Pre-drilled to be used with the Hammerblow Gooseneck Coupler that uses the load bearing pin.

Part No.	Ref. No.	Description
2085205-DRILLED	293798	WALLACE KING PIN 20" PIPE DRILLED PER HB SPECS



BERGEN SLIDE LOCK COUPLER

The Bergen SLIDE LOCK Gooseneck Coupler combines the strength and durability of a pin-lock coupler with the added convenience of a slide-in chute to aid in aligning the gooseneck ball in your pickup when backing up.

Part No.	Ref. No.	Description
2BC	291425	BERGEN SLIDE LOCK GOOSENECK COUPLER 25,000 LBS

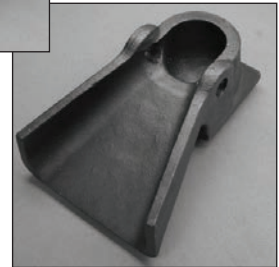

MUMBY EASE-GLIDE CHANNEL COUPLER

Ease-Guide™ trailer couplers are the only trailer coupler that has no moving parts to wear, seize or pinch and offers larger target to set on top of the hitch ball prior to locking the trailer coupler in place. The 2 5/16" Channel Mount Style is rated at 15,000 lbs when installed to manufacturer's specifications.

Also Available in 2" A-Frame and 2 5/16" A-Frame Couplers.

Part No.	Ref. No.	Description
EG2-5/16CHM	305661	MUMBY 2 5/16" CHANNEL MOUNT COUPLER 15,000 LBS

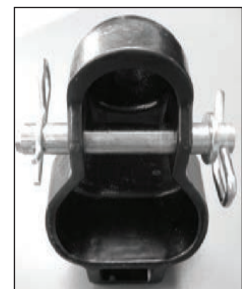

NATIONAL TRAILER PARTS MARINE PRODUCT CATALOGUE

For many years National Trailer Parts Warehouse has been supplying parts to Trailer Manufacturers, Trailer Dealers, and Trailer Repair Shops with one goal in mind; providing the highest level of Selection, Service and Support possible to our customers. It is with that same commitment to our Customer that we are proud to offer our expanded product assortment of Marine Trailer Products and Accessories in this new and exciting catalogue.

Our new Marine Products Catalogue features product from well known and trusted Manufacturers such as Dexter, Fulton, Bulldog, Shelby, Optronics and many others. In this, our first edition, we offer galvanized, zinc coated and stainless steel products because we know such components are essential to the marine community.

We service clients in every corner of Canada; you can be assured that the products you require are readily available.

It is National Trailer Part's goal to continue to explore new and innovative ways to work together with both Customers and Suppliers to ensure a vibrant trailer industry in Canada.



Contact your sales representative for your copy today!

We have an experienced staff at your disposal, who are committed to providing the highest level of service in the industry.

CONTACT US

We always look forward to your feedback, or would just like to hear from you.

- Greg Olson greg@trailerparts.ca
- Ron Elkington ron@trailerparts.ca
- Ryan Bull ryan@trailerparts.ca
- Doug Hall doug@trailerparts.ca
- Mike Heschel mike@trailerparts.ca

National Trailer Parts Warehouse
2494 South Service Road West
Swift Current, SK, S9H 5J8

Phone: (306) 773-4484
Fax: (306) 773-6080
www.nationaltrailerparts.com



THE NATIONAL DIFFERENCE

PEOPLE

Sometimes it seems like we spend more time talking to our customers than we do talking to family. The truth is our customers are like family to us—we experience joy when you experience joy, and feel pain when you feel pain.

This section is dedicated to putting faces to the voices you hear when you call National Trailer Parts.

Something Old.....



James Maxwell

James (On the Right) has been with National Trailer Parts for 14 years. He is shown here receiving his service reward from Wayne Sykes—Supply Chain Manager.

As well as being one of our most seasoned veterans in the warehouse, James also looks after all of our caretaker needs.

James is married to Bev, and together they have 3 grown children, Kara, Blair and Donna, as well as several grandchildren.

Something New.....

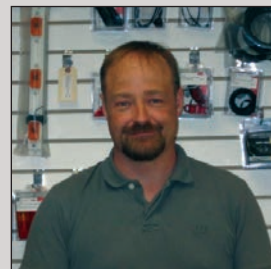

Greg Olson

Greg is the newest member of our sales team. He comes to us with a vast background in Sales, including Auto Parts, RV, & Vehicle Sales.

He also has experience in the oil industry and in logistics, so he understands the needs of a large cross section of our clients.

When Greg is not at work—he enjoys spending time with his two children, Tristan and Mackenzie.